

## ***FC M / E SERIES***

## ***FC M / E \_\_ C SERIES***

## ***FC M / E \_\_ S SERIES***

***AUTOMATIC CONTROL UNIT FOR  
ATMOSPHERIC GAS BURNERS AND  
GAS BURNING APPLIANCES WITH OR  
WITHOUT FAN, WITH INBUILT E.M.C.  
FILTER, REMOTE IGNITOR AND  
OPTOISOLATOR  
(ELECTRICAL OR MANUAL RESET)***

### **Application**

This electronic gas burner control unit has been specifically designed for atmospheric burners for intermittent operation (systems for non-permanent operation), with or without fan in the combustion circuit.

This control unit is provided with volatile or non volatile lockout, i.e. the restart from the safety shutdown condition with volatile lockout can be accomplished by the interruption of the power supply or by means of a new heat demand, whereas with non volatile lockout the restart from the safety shutdown condition can only be accomplished by manual reset, pushing the reset button. This control unit is suitable for the connection with electronic control boards, with insulation between the automatic remote ignition system and the control part at low voltage. As this control unit carries out the correct operation of the ignition burner cycle and flame monitoring, it is suitable to transmit the necessary signals for the control operation by using an optoisolator or optotriac with insulation of 4kV and clearance and creepage distances of the printed circuit board  $\geq 8\text{mm}$  (reinforced isolation).

This control unit is therefore fit to be connected to SELV circuits (Safety Extra Low Voltage e.g. 24V).

This automatic control unit is suitable for:

- boilers;
- warm air generators;
- radiant heaters;
- water heaters.

### **Features**

Followings are the main features of this series:

- EC-Type certification (CE PIN 0085AU0274) in accordance with the Gas Appliance Directive 90/396/EEC and the following amendment 93/68/EEC;
- in compliance with EN 298 (European standard for automatic gas burner control systems);
- remote and highly efficient ignition device (type TR2); (for technical characteristics, see our data sheets "REMOTE IGNITION TRANSFORMERS TYPE TR2");
- inbuilt **EMC filter**;
- remote lockout signal and flame signal facilities;
- flame monitoring by the rectification property of the flame (ionisation).

**PART REFERENCE**

**FC x yy z k w j**

X → M: manual reset  
E: electrical reset

yy → 11: atmospheric without fan and single flame  
12: atmospheric without fan and double flame  
31: atmospheric with fan and single flame  
32: atmospheric with fan and double flame

z → \_: alone use  
C: with female PCB connectors  
S: directly soldering on PCB

k → \_: with protection on reset line (output)  
U: without protection on reset line (output)  
only for manual reset series (M)

w → \_: polarized  
N: not polarized

j → \_: with optocoupler  
Q: without optocoupler

**TECHNICAL DATA**

**Supply Voltage:** 220-240V/50-60Hz  
**Operating temperature range:** -20°C +60°C  
**Ambient humidity:** 95% max at 40°C  
**Protection degree:** IP 00

**Times:**

- Waiting or pre-purge time (**TW**): 1,5 ... 40 s  
- Safety time (**TS**): 3 ... 60 s  
- Ignition time of spark (**TSP**): (TS – 1) s  
- Drop out time on running flame failure: < 1 s

The times given on the control unit label correspond to the values guaranteed. The actual values differ slightly from the values given; waiting or pre-purge time is in fact longer and safety time shorter than their nominal values.

**Starting power consumption:** 13 VA  
**Operating power consumption:** 12 VA

**Contact rating:**

- Thermostat: 4 A cos φ ≥ 0.4  
- EV1: 0.5 A cos φ ≥ 0.4  
- EV2: 0.3 A at 20 °C (\*)  
0.2 A at 60 °C (\*)  
- L/O 0.5 A cos φ = 1  
- Fan 0.5 A cos φ ≥ 0.4

(\*) EV2 driven by optotriac

**Max. length of the cables of external components:**

1m  
**External fuse rating:** 3.15 A quick acting

**Flame control:**

The ionisation flame detection device makes use of the rectification property of the flame.

- Minimum ionisation current: 0.5µA  
- Recommended ionisation current: 3 ÷ 5 times the minimum  
- Max. length of the cable: 1m  
- Minimum insulation resistance of the cable and the flame detection device to earth: ≥ 50MΩ

- Max. stray capacitance of the detection probe: ≤ 1nF  
- Max. short circuit current: < 200µA AC

**Optoisolator:**

- Flame signal current rating: max. 1 mA  
- Max direct voltage: 50 Vdc  
- Max reverse voltage: 5 Vdc  
- Max. length of the cable: 1 m

**Optotriac:**

- Repetitive peak off-state voltage 400 V  
- RMS on-state current (20°C) 300 mA  
- RMS on-state current (60°C) 200 mA  
- Off-state current (100 °C) 100 µA

**Weight:** max 60 g

**Construction**

The varnishing of the printed circuit board protect the control from possible damages resulting from crashes, dust and contact with the external environment.

The use of surface mounting technology (SMT) has allowed to realise a printed circuit board with very limited dimensions; therefore, the control unit has extremely reduced overall dimensions.

The ignition device makes use of the new (**patented**) circuit for discharge generation with remote ignitor, which remarkably reduces the electromagnetic interference emitted in the ignition stage.

A varistor protects the control from voltage transients on the electric network, caused for example by discharges. Internal integrated fuses protects the relays of the control unit in case of short circuits on the outputs (valves). In any case the control must be protected with two external fast blow fuses (each in series to one pole of the mains supply voltage) suitable to the load connected and never exceeding 3.15 A.

**Overall Dimensions – FC M/E SERIES**

The following figure show the overall dimensions of the control unit: Fig. 1 is referred to FC M/E equipped with molex connectors.

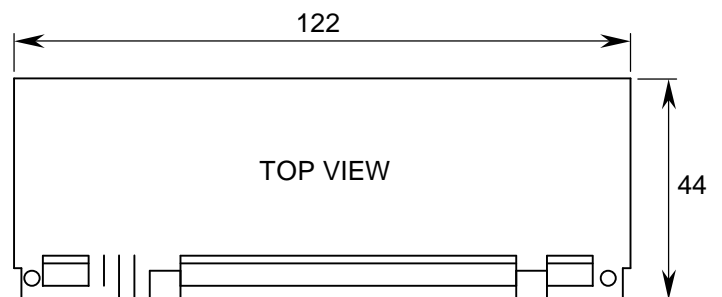

(\*) units: mm.

Fig.1

**Overall Dimensions – FC M/E \_\_ C/S SERIES**

The following figures show the overall dimensions of the control unit: Fig. 2 is referred to FC M/E\_\_C\_ equipped with female molex connectors while Fig. 3 is referred to FC M/E\_\_S\_ (directly soldering version).

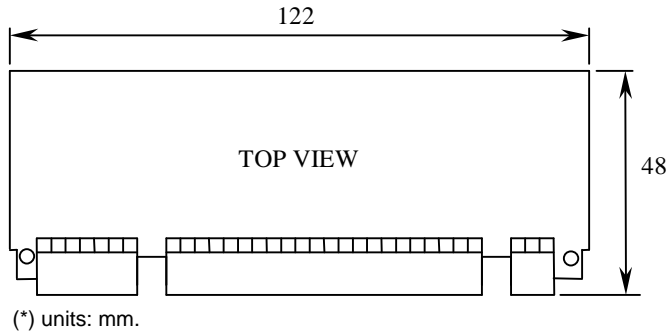

Fig.2

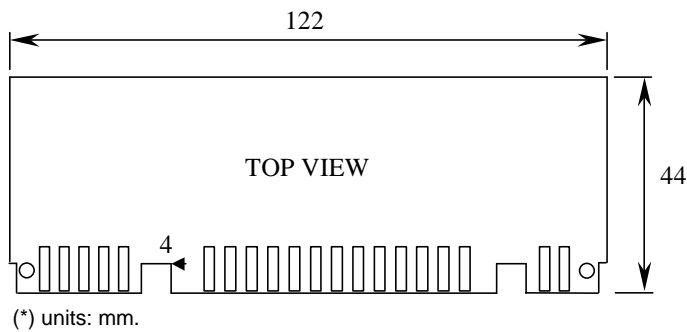

Fig.3

**Accessories – FC M/E SERIES**

- Connectors kit

The control unit is usually supplied with a kit of female connectors with one of thirteen poles and two of two poles, (see Fig.4).

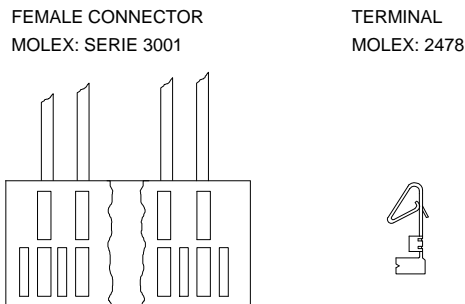

Fig.4

**Connection**

Provisions such as cable holders, sufficient earth terminals and neutral terminals should be present in the appliance or in external connection boxes.

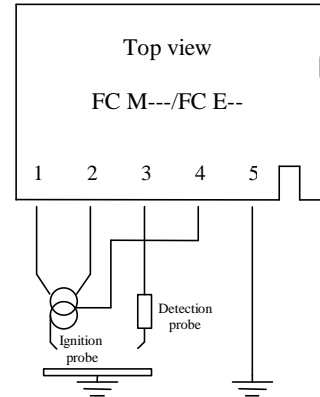

Fig. 5

Fig. 5 shows the connection of separated detection-probe and ignition-probe facility; this connection is valid for all controls type FC M/E, FC M / E \_\_ C \_ and FC M / E \_\_ S \_

**Directions for p.c. board-thermo-regulation design. – FC M/E \_\_ C/S**

The following directions have to be fulfilled in the design of the thermo-regulation p.c. board by which the control is matched:

- Distance between p.c. board routes must be in accordance with IEC 730 – 1 (depending on voltage rating).
- Using the version provided with optoisolator with low voltage signal flame output (FC \_ x1 \_\_), the distance of p.c. board routes connected to pins number 19 and 20 must be at least 8 mm from all the others p.c. board routes, in order to guarantee adequate galvanic insulation. This measure allows to comply requirements of IEC 730 – 1.
- Correct FC p.c. board mounting position is perpendicular to thermo-regulation board; in order to assure electrical safety and FC optimum working conditions and to avoid mechanical interference, all components or mechanical interference, must be kept far at least 5 mm from the highest component profile of the through hole components side and 10 mm from SMD components side.
- To connect FC \_\_ \_\_ C \_ types (with female molex connectors) to p.c. board molex connectors series 3001 have to be used.
- To connect FC \_\_ \_\_ S \_ types (directly soldering on p.c. board ) p.c. board foot-print layout drawn in Fig. 6

### Directions for use

- This automatic control is a safety device and must not be modified. The manufacturer's responsibility and guarantee are invalidated if the control is incautiously modified or illegally broken.
- For technical safety reasons a regulation shutdown must occur every 24 hours (system for non-permanent operation).
- The control can be connected and disconnected only after switching off the power supply.
- Avoid exposing the control unit to dripping water.
- Ventilation and the lowest temperature ensure the longest life of the control.
- Make sure that the model (code, type and times) you are using is correct before installing or replacing the control.

### Electrical installation

- The applicable national and local regulations and the European standards (e.g. EN 60335-1/EN 50165) regarding electrical safety must be respected.
- To guarantee safety live and neutral connections have to be respected.
- The burner control units FC M/E are provided with a polarity detection device which prevents the operation of the control in case of reverse polarity of the mains supply wiring.
- Before starting the system check the cables carefully. Wrong connections can damage the control and compromise the safety.
- Avoid putting the detection cable close to power or ignition cables.
- Use a heat resistant cable and detection probe, well insulated to the earth and protected from humidity (or water in general).
- This control is not equipped with strain relieves; therefore, if required, appropriate strain relieves need to be provided by the appliance in which the control is installed.
- Pins 19 and 20 are low voltage connections on version FC \_ x1 \_ \_.
- This control is equipped with internal fuses, but it has to be fused on live connection at least (see technical data).

In case of "partial" short circuits or bad insulation between live and earth the voltage on the ionisation probe can be reduced until it causes the lockout of the control, because of the impossibility of detecting the flame signal.

### Checking at start

Always check the control before the first start and also after any replacement or a long period of non-operation of the system. Before any ignition attempt make sure that the combustion chamber is free from gas.

Then make sure that:

- if the starting attempt occurs without gas supply the control performs a lockout after safety time (TS);

- when stopping the gas flow while the control is running, the supply to the gas valves is interrupted within 1 second, and after a recycling the control proceeds to lockout;
- operating times and sequence are suitable;
- the level of the flame signal is high enough;
- the ignition probe is adjusted in the most stable way for a spark gap between 2-4 mm;
- the intervention of limiters or safety devices causes a safety shutdown according to the application.

### Operation

At every start the control unit proceeds to a self-checking of its own components. During waiting or pre-purge time (TW) the operation of the flame signal amplifier is checked.

A fault in the amplifier leading to the flame signal condition prevents the control from starting.

At the end of waiting time or pre-purge time (TW) the EV1 gas valve is energised and the ignition device is operated. In this way safety time (TS) and time of spark (TSP) begin.

The ignition device is inhibited about 1 s before the end of TS in all operating conditions (end of TSP). The flame signal output (\*) is supplied at the end of safety time (TS) if a flame signal is detected during this time.

On the contrary, if the control detects no flame signal by the end of safety time (TS), it proceeds to lockout, the EV1 gas valve output is inhibited while the lockout signal output is supplied.

The attached operating cycle diagrams are useful to understand how each control units operate.

(\*) or EV2 output in the double flame controls.



# CONNECTION DIAGRAMS

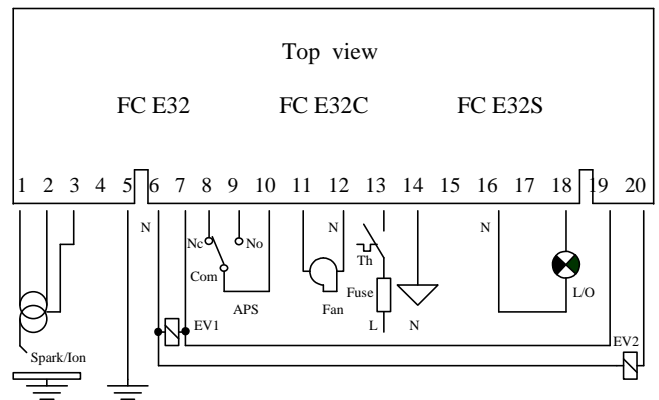
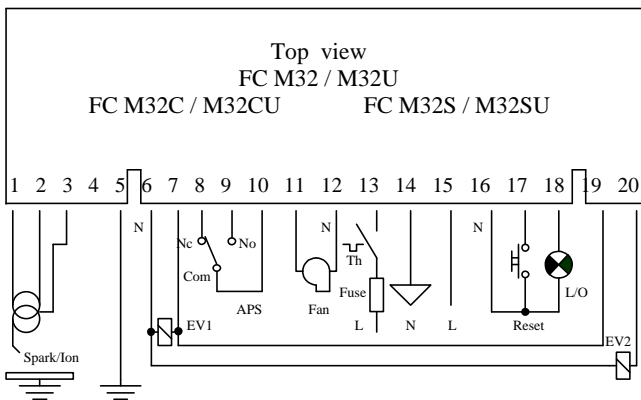
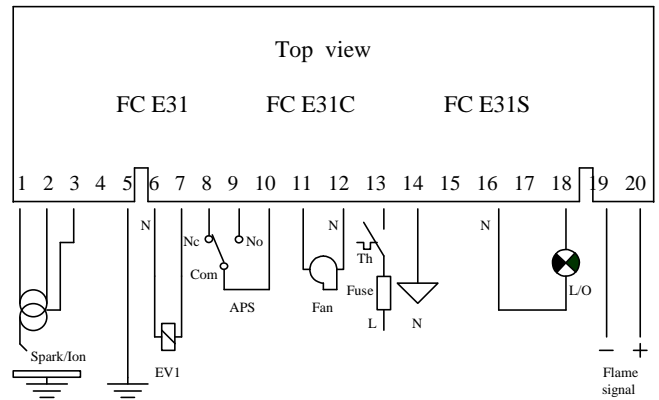
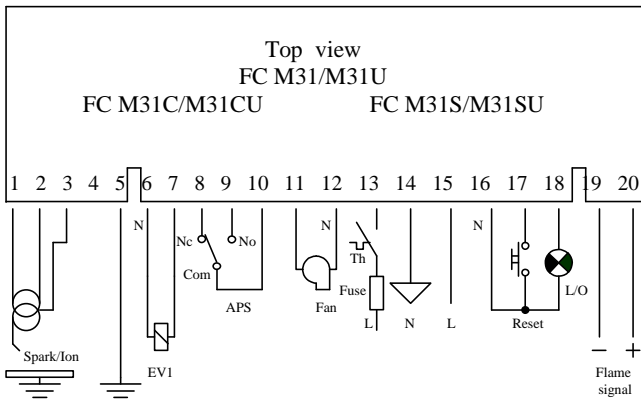
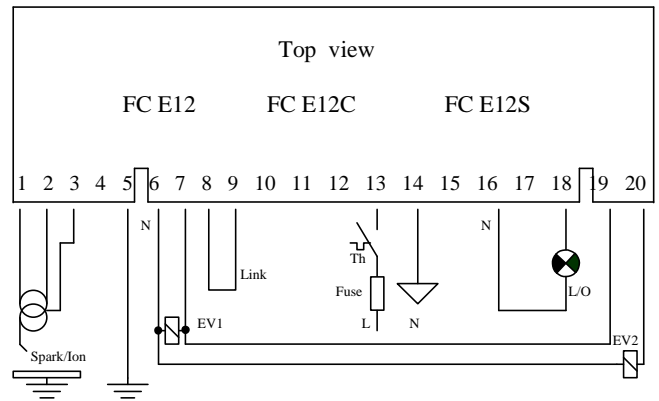
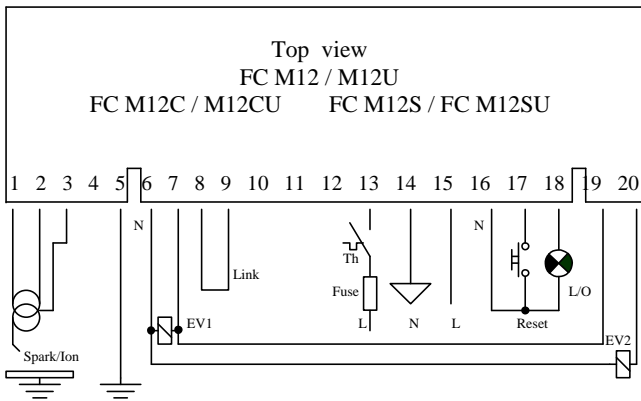
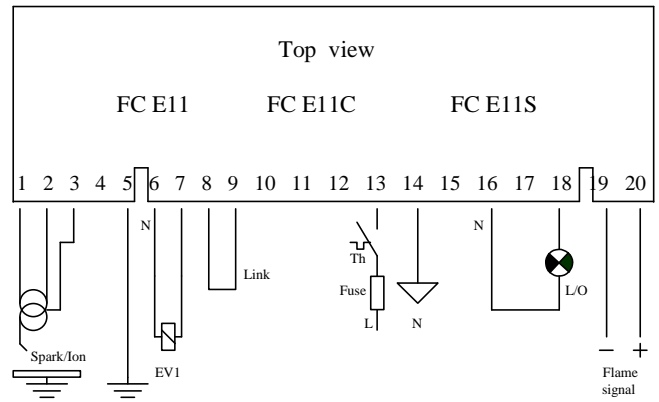
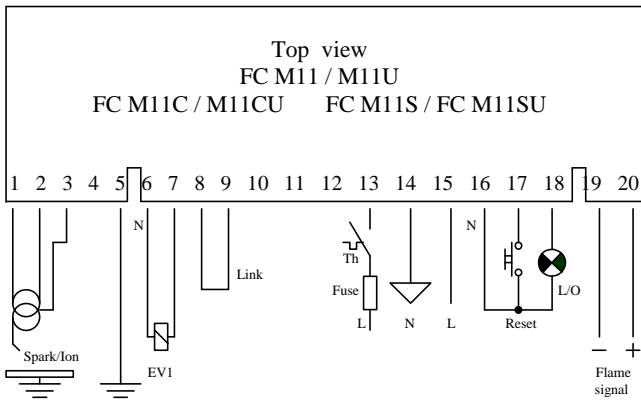

(\*) To connect the flame controls with separated detection-probe and ignition-probe, see Fig 5 on "Connection" paragraphs (bi-electrode connection).

# OPERATING CYCLE DIAGRAMS: MANUAL RESET

FC M11/M11U FC M11C/M11CU FC M11S/M11SU

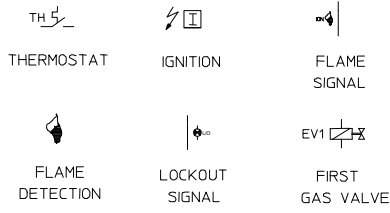
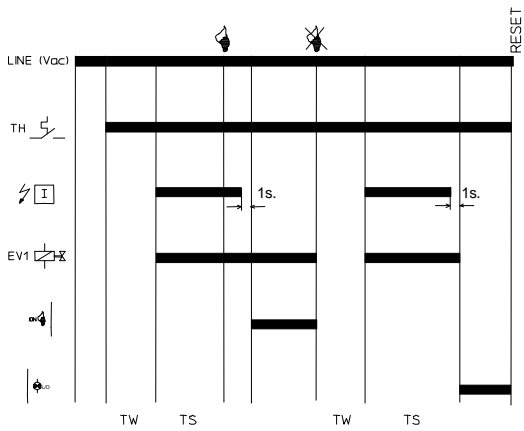

FC M12/M12U FC M12C/M12CU FC M12S/M12SU

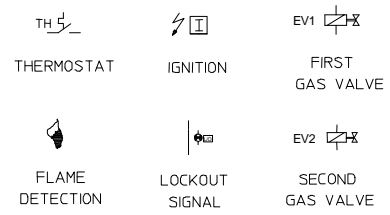
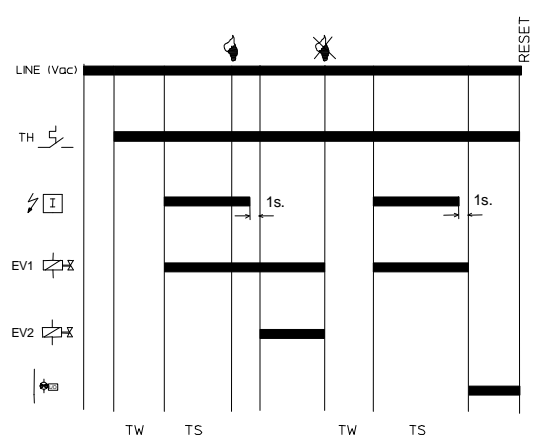

FC M31/M31U FC M31C/M31CU FC M31S/M31SU

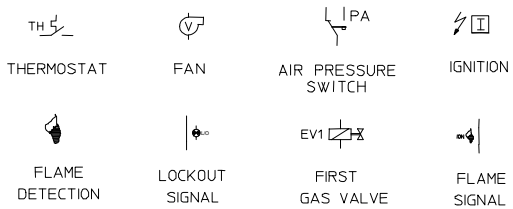
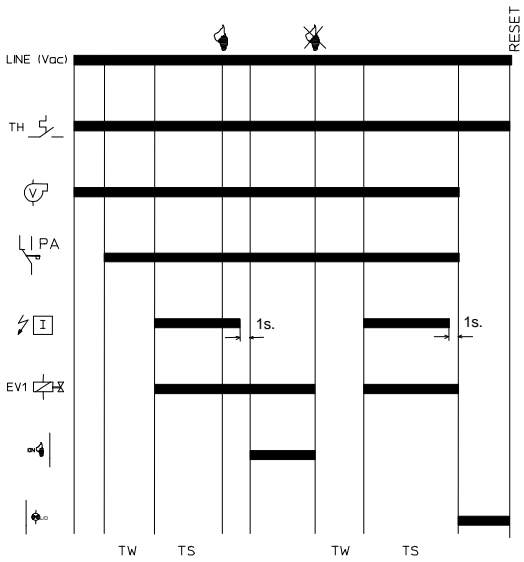

FC M32/M32U FC M32C/M32CU FC M32S/32SU

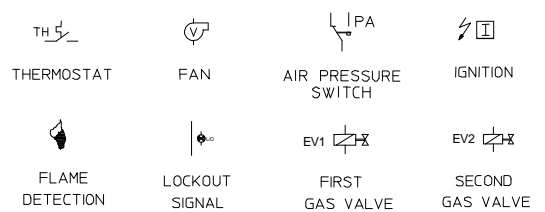
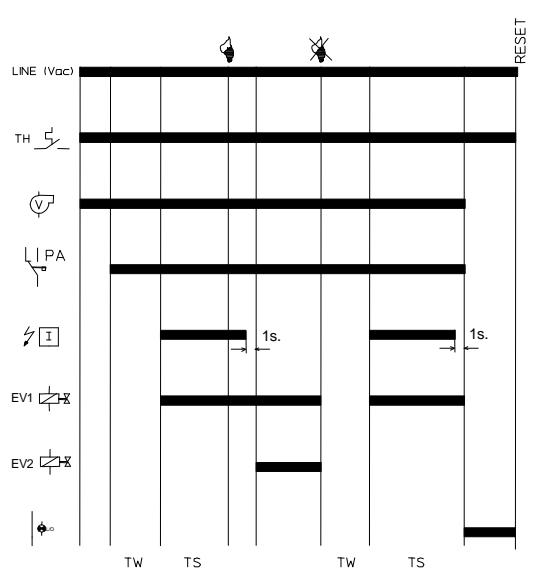

# OPERATING CYCLE DIAGRAMS: ELECTRICAL RESET

FC E11 FC E11C FC E11S

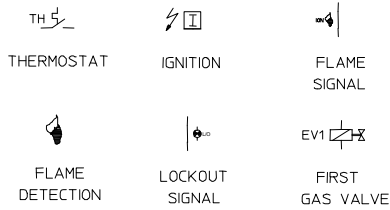
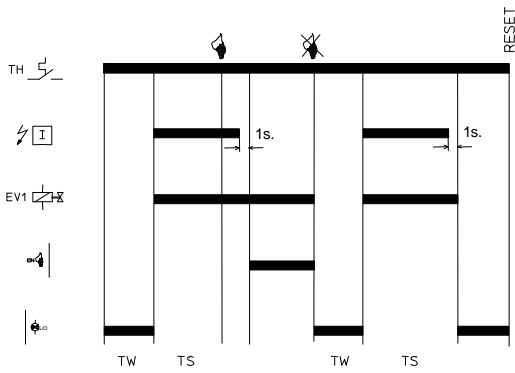

FC E12 FC E12C FC E12S

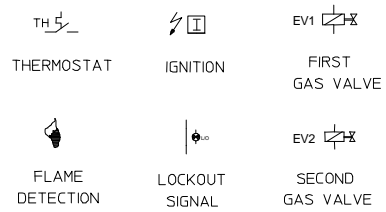
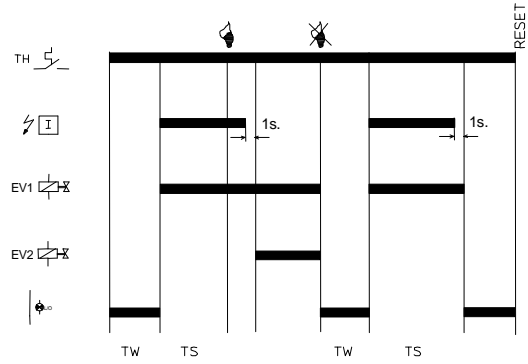

FC E31 FC E31C FC E31S

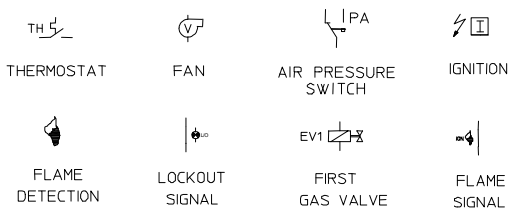
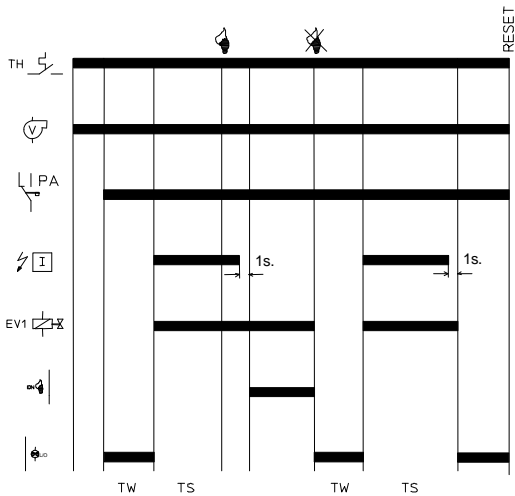

FC E32 FC E32C FC E32S

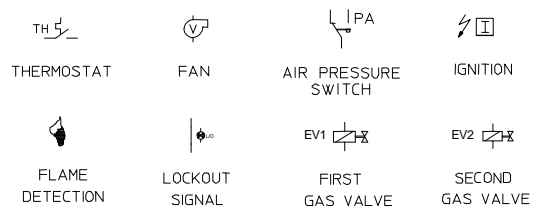
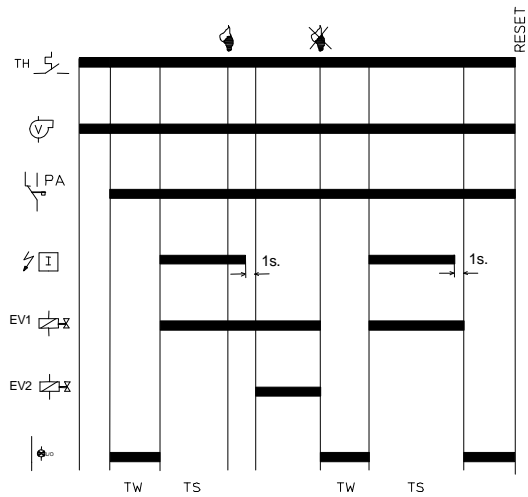

**BRAHMA S.p.A.**  
 Via del Pontiere, 31  
 37045 Legnago (VR)  
 Tel. +39 0442 635211 - Telefax +39 0442 25683  
<http://www.brahma.it>  
 E-mail : brahma@brahma.it

05.10.21 Subject to amendments without notice