

# EUROFLAT SERIES TYPES HS11 HS31 HE11 HE31

## AUTOMATIC GAS BURNER CONTROL SYSTEMS FOR GAS BURNERS AND GAS BURNING APPLIANCES WITH OR WITHOUT FAN

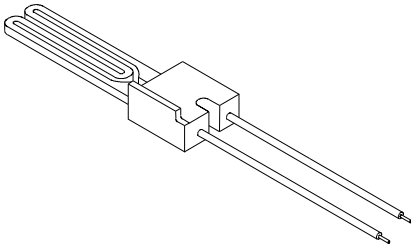
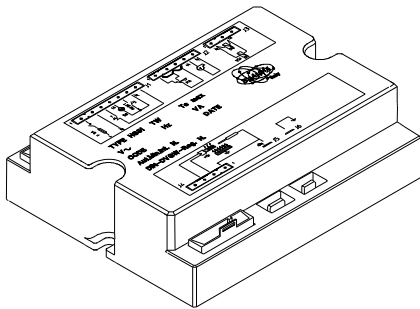
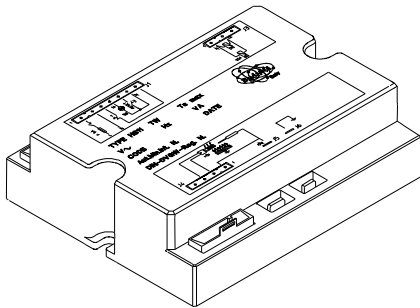

### Application

This range of electronic gas burner control systems has been designed specifically for atmospheric and fan assisted burners for intermittent operation (systems for non-permanent operation).

The control units HS11 and HS31 are provided with **non-volatile** lock-out, which means that a restart from the safety shut-down condition can only be accomplished by a manual reset of the system. The control units HE11 and HE31 are provided with **volatile** lock-out, which means that a restart from the safety shut down condition can only be accomplished by an interruption of the main power and its subsequent restoration.

These types of automatic burner control units differ from the standard model essentially in the operating cycle and in the features of the ignition-detection device. Using a single device for detection and ignition, they could be considered as single probe controls. If necessary, anyway, they can operate correctly also with a separate detection probe while the hot surface ignition device (HSI) is only used for the ignition. Due to the design and the technical-structural characteristics, the controls of this series can be used in general in gas firing installations with atmospheric burner.

### Features

Table 1 shows the main features of this series. Other important features are:

- EC - Type certification (CE Reg. N° 63AQ0625) in accordance with Gas Appliance Directives 90/396 and 93/68;
- in accordance with EN298 (European standard for automatic gas burner control systems);
- flame monitoring by the rectification property of the flame: ionization;
- electrical service life at max. loading >250.000 operations;

TABLE 1

	BURNER			OPTIONS		classification code according to EN298
	single flame	atmospheric without fan	atmospheric with fan	non-volatile lock-out	volatile lock-out	
HS 11	*	*		*		AMC LXN
HS 31	*		*	*		FMC LXN
HE 11	*	*			*	AMC VXN
HE 31	*		*		*	FMC VXN

## TECHNICAL DATA

**Supply Voltage:** 230V-50/60Hz  
**Operating temperature range:** -20°C +60°C  
**Ambient humidity:** 95% max at 40°C  
**Protection degree:** IP 00

### Times:

-Warm up time (TR): 30 s  
 -Safety time (TS): 5 s  
 -Drop out time on running flame failure: < 1 s

The times given on the burner control label correspond to the values guaranteed. The actual values differ slightly from the values given, warm time is in fact longer and safety time shorter than their nominal values.

### Power consumption, at starting up:

atmospheric burner 700 VA  
 atmospheric fan-assisted burner 710 VA

### Power consumption, running:

atmospheric burner 9 VA  
 atmospheric fan-assisted burner 12 VA

### Contact rating:

1 max

-Thermostat: 6 A  $\cos \varphi = 0.4$   
 -VG1: 0.5 A  $\cos \varphi = 0.4$   
 -Fan: 1 A  $\cos \varphi = 0.4$   
 -Alarm: 0.5 A  $\cos \varphi = 1$

### Max. length of the cables of external components:

1 m

**Fuse rating internal:** 6.3 A T

**Fuse rating external:** 5 A F

### Flame control:

The ionization flame detector device makes use of the rectification property of the flame.

The ionization flame detector device is not a safe to touch output (no provision with protective impedances).

-Minimum ionization current: 1.2µA  
 -Recommended ionization current: 3 ÷ 5 times the minimum ionization current

-Max length of the cable: 1 m  
 -Minimum insulation resistance of cable and flame detector device to earth:  $\geq 50M\Omega$

-Max. parasitic capacitance of detection probe:  $\leq 1nF$

-Max. short circuit current: < 200µA AC

### Hot surface ignition device:

-Part number: 15912000  
 -Model: 11230-100-8008  
 -Consumption : 1.8 ÷ 3 A  
 -Time to reach 1150°C: <30" (typically 20")

-Resistance at 20°C: 600 Ohm max  
 -Operating temperature: 1090 ÷ 1540°C  
 -Max temperature: 1600°C

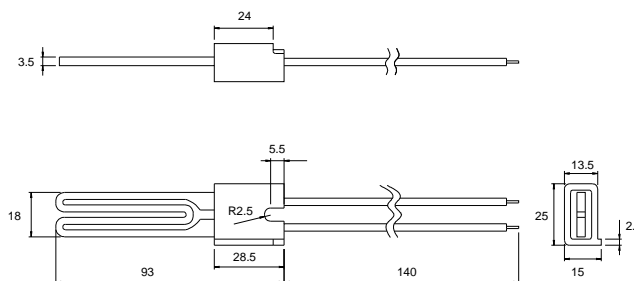

Fig. 1

**Weight:** 200 g

### Controls for special applications:

On request it is possible to meet special requirements concerning times, minimum ionization current and operating cycle.

### CONSTRUCTION

The enclosure made of plastic material protects the control from mechanical damage, dust and dirt from the conditions of installation.

The printed circuit board dimensions have been reduced by means of a module with surface mounted components.

A varistor protects the control from voltage transients on the mains supply. An internal fuse protects the relays of the control box in case of short circuits on the outputs (valve, fan, lock-out signal and ignition device). This is not an accessible fuse and the control must be protected with a fuse of the fast blow type suitable to the load connected and never exceeding 5A.

### Overall Dimensions

The following figure (Fig. 2) shows the overall dimensions of the controls.

Fig.2

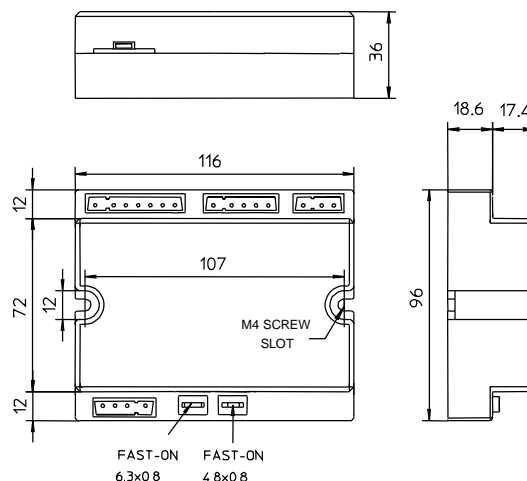

### Accessories

The control units are usually supplied with a kit of female connectors and/or reset button. Do not fit terminals and female connectors of different types.

These accessories can be supplied upon request (see Fig.3).

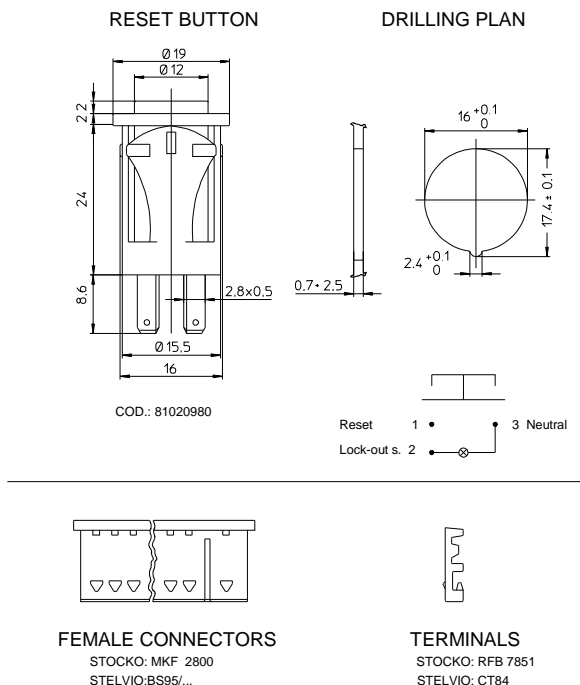

Fig.3

### Connection

Using non reversible connectors with different number of poles makes the connection easy and reliable.

Regarding the connection of the control units, provisions such as strain reliefs, sufficient earth terminals and neutral terminals should be present in the appliance or in external connection boxes.

### DIRECTIONS FOR THE USE

- For technical-safety reasons a regulation shutdown must occur every 24 hours (systems for non-permanent operation).
- Automatic controls are safety devices and shall not be opened. Responsibility and guarantee of the manufacturer is invalidated if the control is opened.
- The control must be connected and disconnected only without the main power.
- The control can be mounted in any position.
- Avoid exposure of the control unit to dripping water.
- Ventilation and the lowest temperature ensures the longest life of the control.
- Make sure that the type (code and times) you are using is correct before installing or replacing the control.
- The gas appliance in which the control is installed must provide adequate protection against the risk of electrical shock (at least IP20).

### Electrical installation

- The applicable national regulation and European standards (e.g. EN60335-1/prEN50165) regarding electrical safety must be respected.
- Live and neutral should be connected correctly, a mistake could cause a dangerous situation, i.e. the valve would still be live with the thermostats and limits switched off. Besides, if live-neutral polarity is not respected the control performs a non-volatile or volatile lock-out at the end of the safety time at starting up.
- Before starting check the cables carefully. Wrong connections can damage the control and compromise the safety.

- Take great care while connecting the lock-out signal and reset button: an inversion in the connection can damage the control.
- The earth terminal of the control, the metal frame of the burner and the earth on the mains supply must be well connected.
- Use an ignition cable as short and straight as possible and keep it far from other conductors.

In case of live-neutral network with unearthed neutral or live-live network (with centre of the star not earthed) the control can operate correctly by means of a built-in resistor.

**IMPORTANT: in the event of "partial" short circuits or bad insulation between phase(s) and earth the voltage on the ionization device can be reduced until it causes the lock-out of the control.**

### Checking at start

Always check the control before the first start and also after substitutions or a long period of non operation of the system. Before any ignition attempt make sure that the combustion chamber is free from gas.

Then make sure that:

- if the attempt to start occurs without the gas supply the control performs a non-volatile or volatile lock-out after TS;
- when stopping the gas flow (while the control is in running state) supply to the gas valve is interrupted within 1 second and after a recycling, the control proceeds to a non-volatile lock-out;
- operating times and sequence are suitable;
- the level of the flame signal is sufficient, see Fig.4 for the measuring test;
- the intervention of limiters or safety devices causes a safety shut-down according to the application.

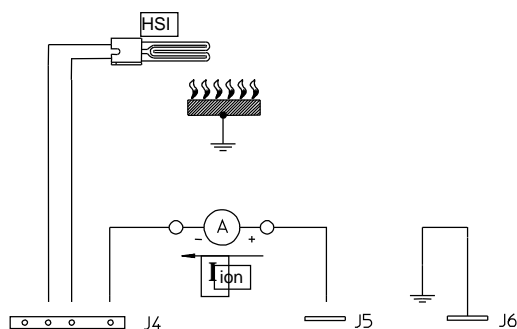

Fig.4

### Operation

At every start the control unit proceeds to a self-checking of its own components.

In the types with control of the fan, before the elapsing of warm up time, the air pressure switch contacts are checked to prove their "no air flow" state.

Only if the test is positive the fan is started and with the air pressure switch in "air flow" state, warm up time begins.

When warm up time begins, the heating phase of the HSD starts; this phase continues during the lapse of warm up time and partially of safety time, approssimately the 70% of it. When this phase is completed, the control interrupts the supply to the HSD and connects it to the detection terminal for the remaining 30% of safety time, in this way using it as an electrode to detect the flame signal.

At the end of warm up time the gas valve is supplied and the ignition device, that in the mean time has reached the thermic operational state, allows the gas ignition.

If a flame is detected during TS, the control unit will keep the gas valve supplied until a flame failure occurs (followed by a recycling) or the regulation ring opens.

On the contrary, if the control doesn't detect a flame by the end of TS, it proceeds to non-volatile (or volatile) lock-out, the gas valve is switched off while the lock-out signal output is supplied.

The attached diagrams are useful to understand how each control operates.

#### **Reset of the control**

When a control has gone to non-volatile or volatile lock-out, an interval of 10 seconds should be allowed before attempting to reset the control unit; if this time is not observed then the control may not reset correctly.

In case of volatile lock-out, the restart from the safety shut-down condition can only be accomplished by an interruption of the main power and its subsequent restoration.

The volatile lock-out models do not contain an independent manual reset function. The application of these types of controls is therefore restricted to only those appliances where resetting by switching off the heat demand is allowed by European standards.

In general, resetting of the appliance must occur in sight and in the near vicinity of the appliance. Resetting must also occur by means of a conscious manual action and not by means of automatic device like thermostats or timers.

Please note that it is allowed to combine the reset button together with the main switch on the appliance. In this case the alarm light will have to be installed too.

# CONNECTION DIAGRAMS

## Configuration with single electrode

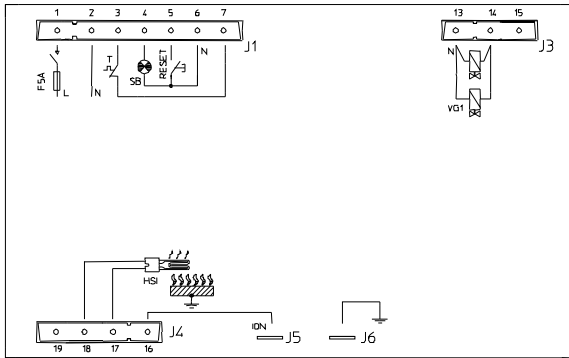

TYPE HS11

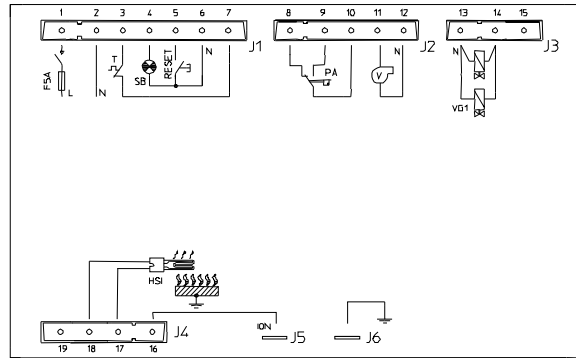

TYPE HS31

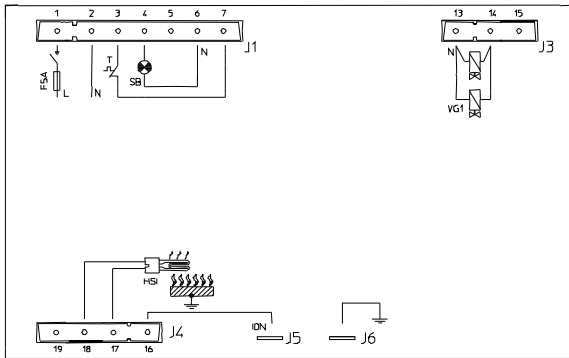

TYPE HE11

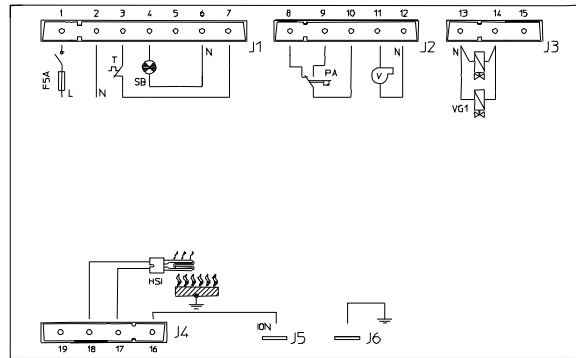

TYPE HE31

## Configuration with separate detection electrode

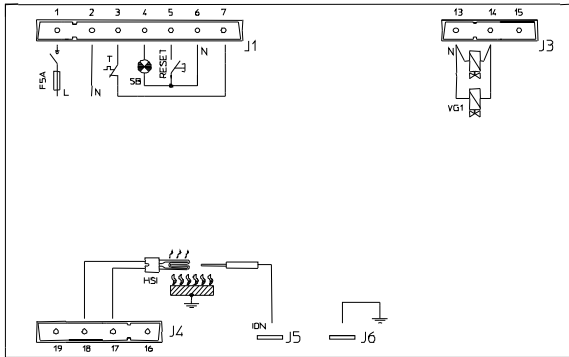

TYPE HS11

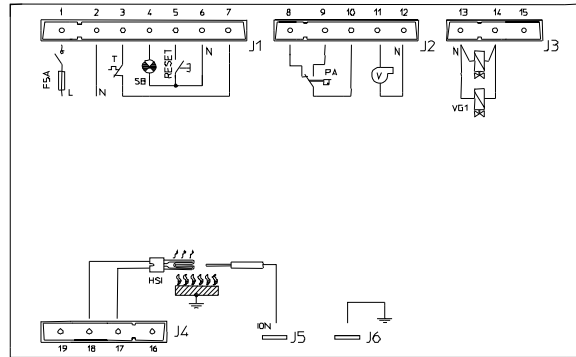

TYPE HS31

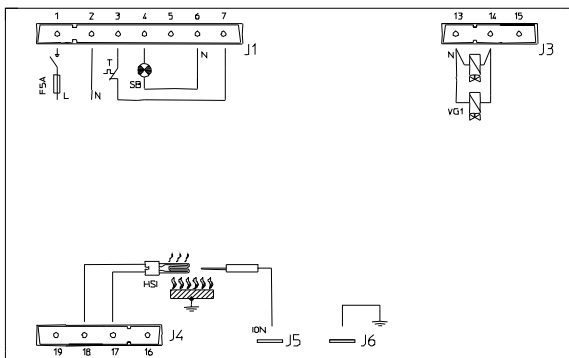

TYPE HE11

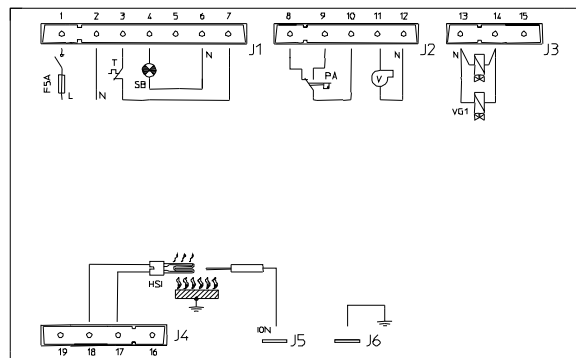

TYPE HE31

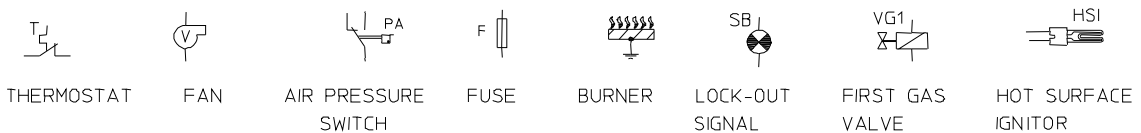

**NOTE:** the limit thermostat has to be wired in series to the live.

# OPERATING CYCLES

## Configuration with single electrode

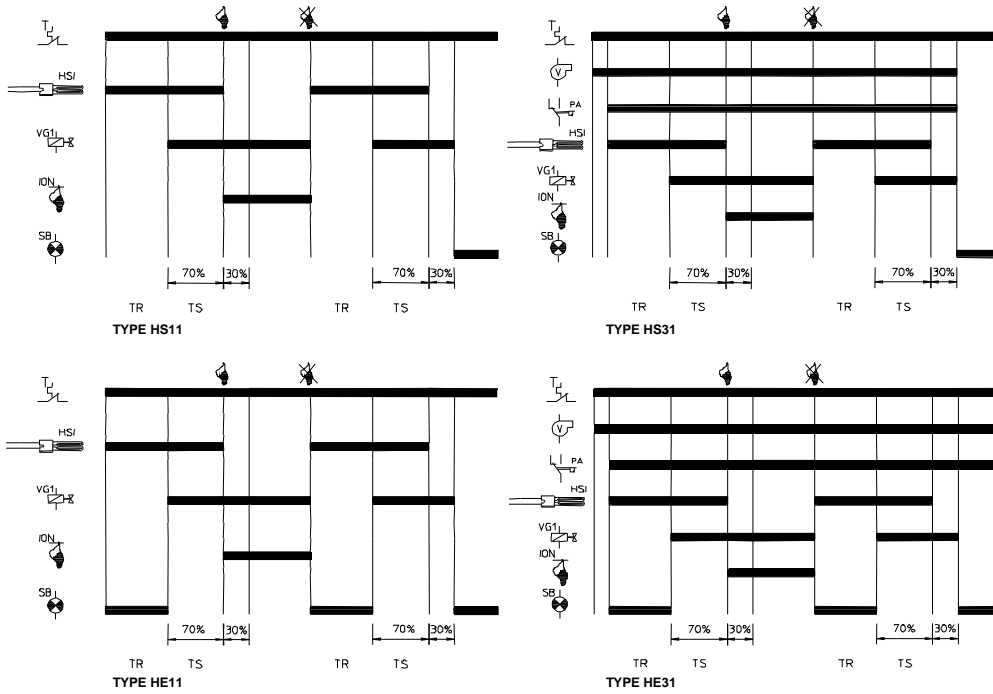

## Configuration with separate detection electrode

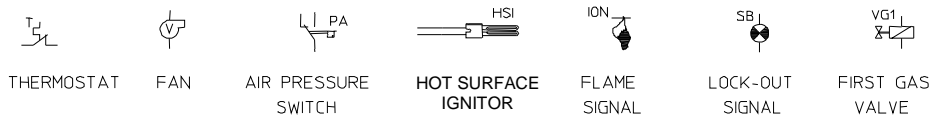
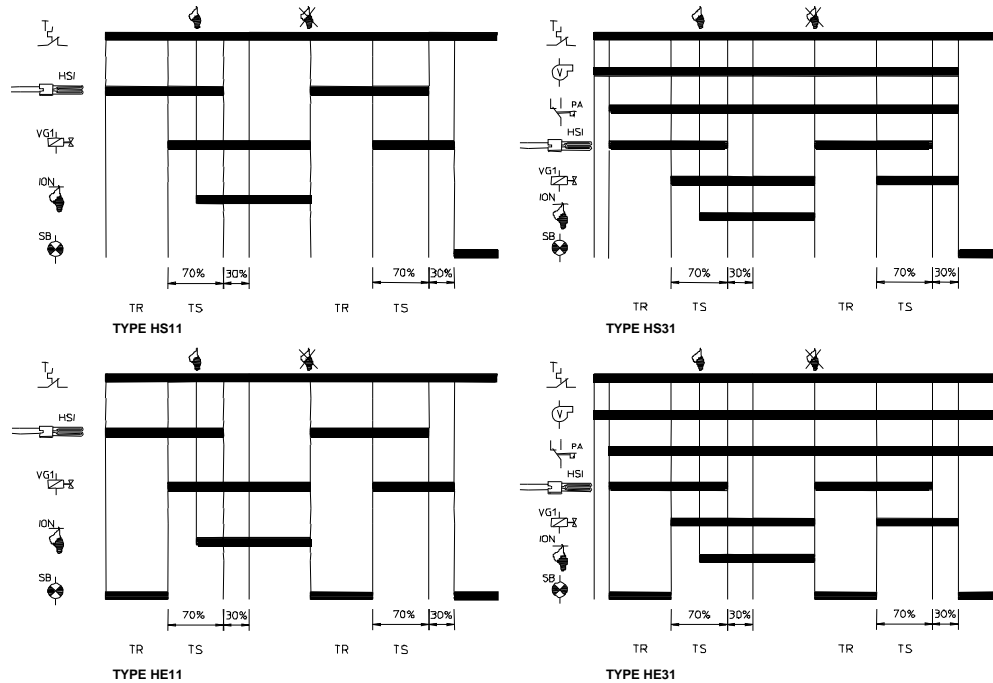

## Euroflat Series Types HS.. HE..

**BRAHMA S.p.A.**  
Via del Pontiere, 31  
37045 Legnago (VR)  
Tel. +39 0442 635211 - Telefax +39 0442 25683 - 635256  
<http://www.brahma.it>  
E-mail : [brahma@brahma.it](mailto:brahma@brahma.it)

02/04/16 Subject to amendments without notice