

DIGITAL CONTROLLER FOR SOLAR THERMAL SYSTEMS



DESCRIPTION

Programmable digital controller for solar thermal systems with one solar collector, one circulation pump, one tank and heating integration.

This device works as a temperature differential regulator and it is able to optimize the solar system performances thanks to the possibility to drive a modulating pump and to offer several functions for the system protection.

The simple design and the user interface friendliness make the RS02 a product suitable for standard solar thermal systems.

GENERAL FEATURES

- 7 segments display with 2 digits
- 3 leds for diagnostic/working status
- 3 push buttons for regulations
- 3 inputs for PT1000 or NTC (10K@25°C $\beta=3435$ or 1,65K@80°C $\beta=3530$) temperature probes
- 2 outputs :
 - 1 relay N.O. (free contact power) output
 - 1 triac (high voltage) output
- SELV (Safety Extra Low Voltage) insulation
- possible wall fitted or in a control panel

TECHNICAL DATA

Power supply:	230V-50/60Hz
Operating temperature:	-20°C +60°C
Humidity:	95% maximum @ 40°C
Protection degree:	IP 30
Weight:	200g
PT1000 temperature range:	from -40°C to 250°C
NTC temperature range:	from -40°C to 105°C
N.O. contact:	max 1A 250Vac $\cos\phi=0.4$
TRIAC output:	max 1A 250Vac
Thermofuse protection:	3,15A/250V (with loads)
Dimensions:	100x70x36,2mm

ACCESSORIES

The system can be supplied with:

- contact or immersion temperature probes type NTC;
- temperature probes type PT1000.

CONSTRUCTION

This device consists of a control board with push buttons, display and leds which let the users or installers set up and watch the status of the system. The control board is placed in a plastic box suitable for wall fixing and it's equipped with a cover to protect push buttons and display.

MECHANICAL DIMENSIONS

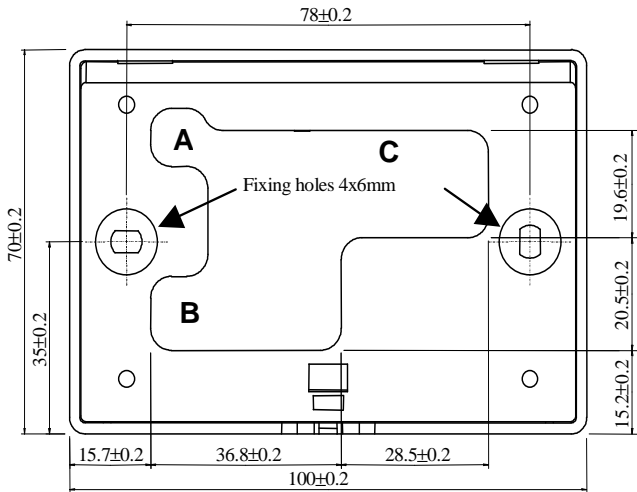
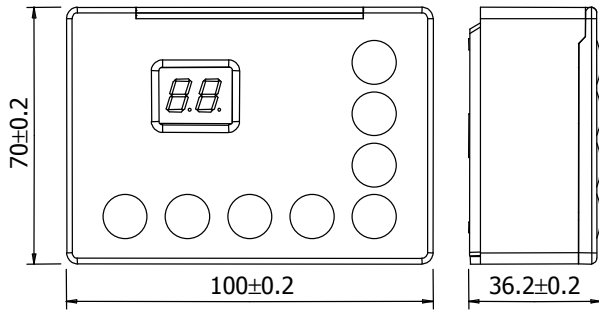

INDICATIONS FOR THE INSTALLATION

- Respect the national and european applicable normative (es.EN60335-1/prEN50165) related to electrical safety.
- Respect line (L) and neutral (N).
- Pay attention to cable connections; wrong connections may damage the device and jeopardize the solar system safety.
- Connect and disconnect wirings in absence of power supply only.
- The controller can be mounted in every position.
- The controller must be located in dry interior locations.
- Make Ground connection on the apposite fast-on connector: 90° fast-on connector oriented towards terminal box J1 is advised.
- Pay attention to separate routing of sensors cables and mains cables.

Suggestion:

The cable connected to terminal box J3 has to be pulled out from the zone marked with A of the bottom cover hole, the cables connected to terminal boxes J2 and J4 from zone B and the cables connected to terminal boxes J1 from zone C.

DESCRIPTION

- **User side:** (figure 1)

2 digit displays (DL1), three leds (LD1 green, LD2 and LD3 red) and three push buttons (S1, S2 and S3).

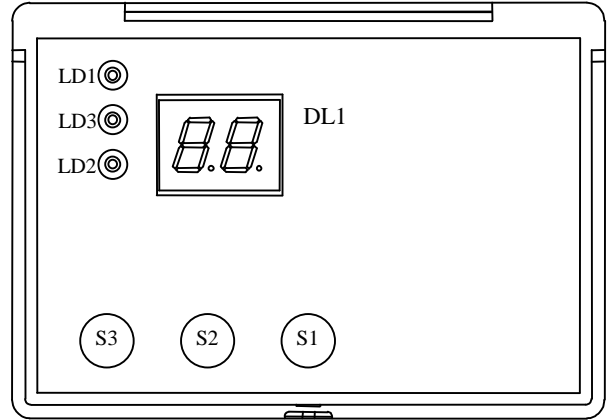

figure 1

- **Technician side :** (figure 2)

- J1 temperature probes connector;
- J3 power supply connector (L = line, N = neutral);
- J2 modulating output connector (U1);
- J4 free contact power output connector (U2).

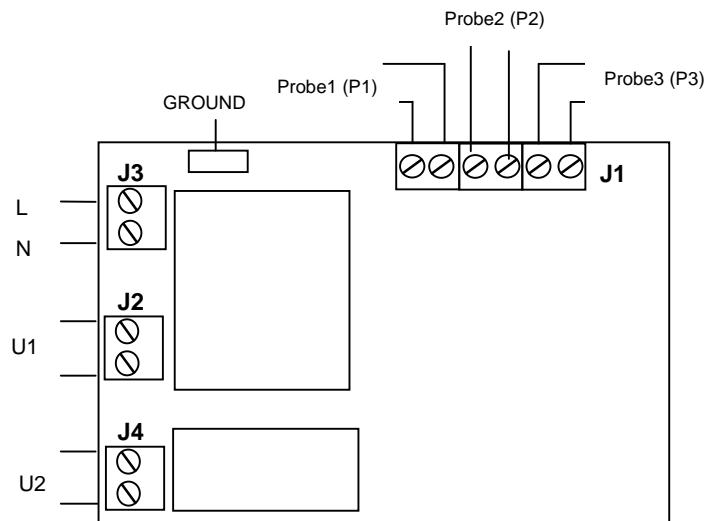

figure 2

VISUALIZATIONS AND COMMANDS

- Commands (figure 1) :

S1: button **OK**;

S2: button **+**;

S3: button **-**;

- Visualizations (figure 1):

LD2 on: thermostat active;
LD2 off: thermostat not active;
LD3 on: pump active;
LD3 off: pump not active;
LD3 e LD2 flashing: faults;
LD1 on: power supply status.

- Fault indications

Here below are shown the fault indications appearing (flashing) on the display in case of the system anomalies; they are reported in decreasing priority order:

E1: storage tank over temperature;
E2: collector over temperature;
E3: tank top temperature probe in open circuit;
E4: tank top temperature probe in in short circuit;
E5: tank bottom temperature probe in open circuit;
E6: tank bottom temperature probe in short circuit;
E7: collector probe in open circuit;
E8: collector probe in short circuit;
EP: pump anomaly;
Er: relay anomaly;
EE: microprocessor memory error.

If there are two or more errors at the same time, the error having higher priority will be displayed .

Other faults:

00: temperature measured is below 0°C;
99: temperature measured is over 99°C.

OPERATING PROGRAM

The main target of the solar controller is to control, to optimize and to storage the thermic energy from the sun. RS02 controller, even if with its simplicity, satisfies this request and works in a very practical and intelligent way, thanks to the possibility to modulate the pump; moreover, in case of a poor irradiation from the sun, manages automatically heating integration like a traditional boiler.

RS02 operating program

When the power supply is switched on LED1 (green) turns on and indicates that RS02 is ready to operate.

To enter in the menu push **OK** push button. The menu is very simple and contains essential parameters to set-up.

To scroll the menu push **+** or **-** push buttons.

To modify a parameter push first **OK** push button, and then, when the parameter is flashing, to modify it push **+**

or **-** push buttons.

To confirm the value changed push **OK**.

If no push buttons have been pushed for 10 seconds the controller exits from the menu.

Operation parameters

Solar system type

ot (operation type) indicates the solar system type:

- t0: solar system OFF;
- t1: standard solar system;
- t2: solar system with heating integration.

If the system is off (t0 selected) the display shows SY (stand-by), and, if you push **+** or **-** , the storage tank temperature is shown for 5 seconds and then SY returns.

If the system is on (t1 or t2 selected) the display shows the storage tank temperature probe and the software algorithm works as follow:

The pump is on when $P1 > P2$ and Delta between these two probes is $> 5^{\circ}\text{C}$.

The pump is off when $P1 > P2$ and Delta between these two probes is $< 2^{\circ}\text{C}$.

When the system works with a modulating pump its speed is increased of 5% each time the temperature difference between $P1$ e $P2$ is upper than others 5°C plus the first Delta.

Just for the system t2, when $P3 < th$ parameter the heating integration is activated. To avoid continuous thermostat on/off an hysteresis of 5°C has been set.

Output

If t1 is selected, output U2 is activated together with output U1, so the pump, if it is a ON/OFF type, can be connected indifferently on U2 or U1 (parameter ct has to be set on c1). To modulate the pump, the right connection is on U1 and ct has to be set on c0.

If t2 is selected outputs U1 and U2 are independent: U1 for solar pump (modulating or ON/OFF), U2 for thermostat only.

Storage tank set-point

bt indicates the storage tank temperature set-point.

Pump

ct indicates the way how to drive the pump, in particular:

- c0: to modulate the pump: minimum speed is set automatically at 50% of the max speed;
- c1: ON/OFF pump: minimum speed is set automatically at 100% of the max speed .

Thermostat (only for t2 solar system)

th indicates the minimum storage tank temperature below which the boiler is activated.

Probe types

P1 (probe 1), **P2** (probe 2) and **P3** (probe 3) indicate respectively the type of probes the system will work with.. P1 (collector probe), P2 (bottom storage tank probe) and P3 (top storage tank probe).

The type can be:

- b0: probe type PT1000;
- b1: probe type NTC with $\beta=3435$ ($10k@25^{\circ}\text{C}$);
- b2: probe type NTC with $\beta=3530$ ($1,65k@80^{\circ}\text{C}$).

Loads test

tL (test Loads) is used only during the solar system installation or diagnostic operation in order to test the correct load working, in particular:

- L0: test not active (solar system is working);
- L1: test pump;
- L2: test thermostat (only for t2 program).

When tests are completed, $tL=L0$ must to be set.

The following table shows a summary of the parameters described above.

PARAM	DESCRIPTION	DEFAULT	RANGE	t1	t2
Ot	PLANT TYPE – ON/OFF	t1	t0,t1,t2	X	X
Bt	TANK SET-POINT	60°C	10 / 90	X	X
Th	TEMP.THERM OSTAT. ON	40°C	10 / 90		X
Ct	PUMP TYPE	c0	c0,c1	X	X
P1	TYPE PROBE1	b2	b0,b1b2	X	X
P2	TYPE PROBE2	b2	b0,b1b2	X	X
P3	TYPE PROBE3	b2	b0,b1b2	X	X
tL	LOADS TEST	L0	L0,L1,L2	X	X

Optional functions

Optional functions are set in the controller (both on by default):

- collector cooling: if the collector probe is measuring a temperature above 120°C, the pump is activated at 100% to cool the solar collector;

- storage tank cooling: if the collector probe is measuring a temperature above setpoint and the collector temperature is almost 5°C below the storage tank temperature, the pump is activated at 100% to cool the tank.

Protections

The control system provides the following protections:

- no frost: if the collector probe is measuring a temperature under –10°C the pump is activated at 100% of the max speed;
- collector over temperature: if the collector probe is measuring a temperature over 140°C, the pump turns off and error E2 is displayed;
- storage tank over temperature: if the bottom tank probe is measuring a temperature over 95°C the pump turns off and error E1 is displayed;
- pump anti-locking: if the pump has not be activated for 24 hours, it is activated at 100% for 1s.

APPENDIX: SELECTABLE SOLAR SYSTEMS

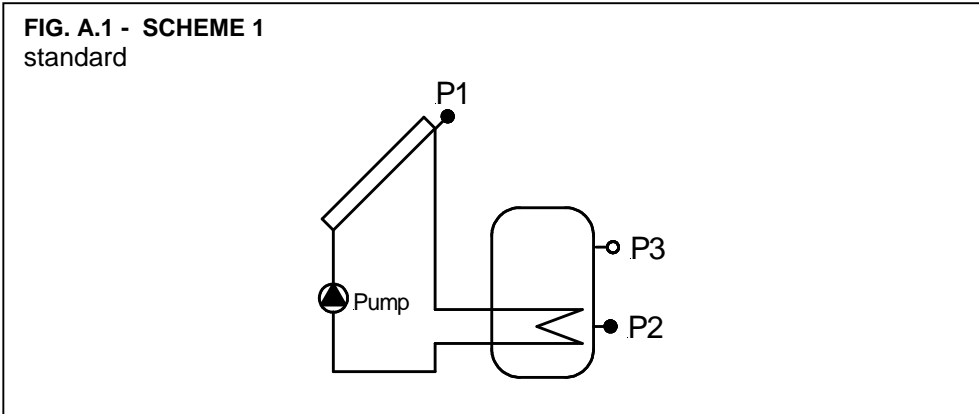

1 storage tank	
1 pump	
2 probes	
P1	collector probe
P2	bottom storage tank probe
P3	top storage tank probe (optional)
Pump	solar pump (output U1 or U2)

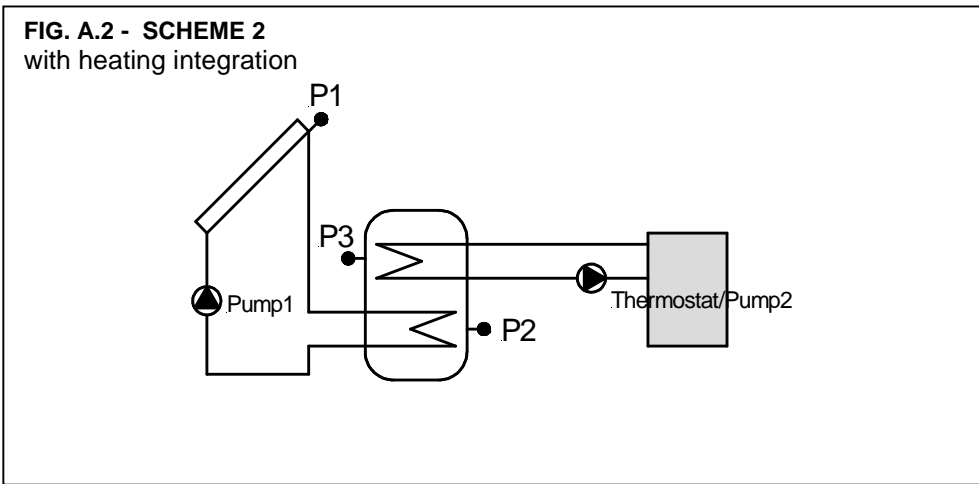

1 storage tank	
1 pump	
1 heating thermostat	
3 probes	
P1	collector probe
P2	bottom storage tank probe
P3	top storage tank probe
Pump1	solar pump (output U1)
Thermostat/ Pump2	heating thermostat (output U2)

ATTENTION -> Brahma S.p.A. accepts no responsibility for any damage resulting from customer's tampering with the product.

BRAHMA S.p.A.
Via del Pontiere, 31
37045 Legnago (VR)
Tel. +39 0442 635211 - Telefax +39 0442 25683
<http://www.brahma.it>
E-mail : brahma@brahma.it

10/05/10 Subject to technical changes