

# KOMPACT Series

## Types TGRx

### AUTOMATIC OIL BURNER CONTROL SYSTEMS

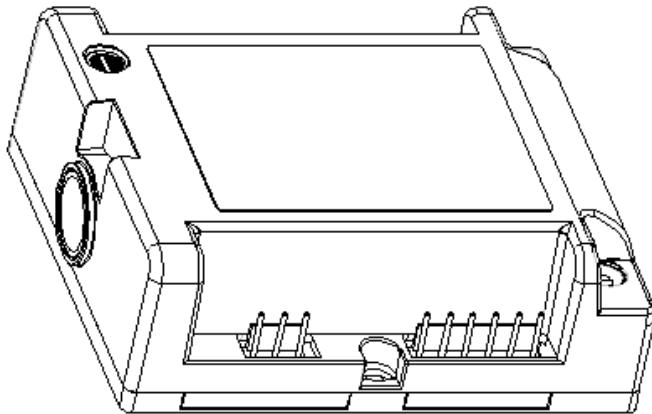

#### APPLICATION

The electronic devices of this series are developed thanks to the success obtained during the years from two products: the oil burner control system type GRx and the ignitor transformers type TC2x and TD2x. This merging has permitted to obtain a device extremely compact, easy to install and with a low cost.

This range of electronic oil burner controls has been specifically designed for oil burners for non permanent operation.

The automatic burner controls of this series are suitable for:

- monobloc oil burners
- warm air generators
- steam boilers
- power washers
- kilns

Due to the technical and structural characteristics and to the variety of models they can be used for the automation of cookers and oil burner operated appliances for domestic and industrial applications.

#### FEATURES

Table 1 shows the main features of this series.

Other important features are:

- in accordance with the European standard DIN EN 230: 2005 concerning monobloc oil burners, safety control and regulation devices. The DIN registration numbers relevant to this series of devices are the following:  
 type TGR1x **DIN Reg. No. 5F218/07**  
 type TGR2 **DIN Reg. No. 5F219/07**
- in compliance with the standard DIN 4794 part 2, edition December 1980 regarding warm air generators WLE (only version with TV = 20s and TS = 5s);
- two independent safety contacts for oil valve(s) control;
- electrical service life at max load >250.000 operations;
- integrated electronic ignitor transformer with EMI suppression filter;
- simple wiring and installation.

**TABLE 1**

|       | Single flame | Dual flame | Pre-heater | Fuel throughput < 30kg/h | Fuel throughput > 30kg/h | WLE | External reset | Flame detectors: FC11/. FC13/. FC14/. FD1 FD2 | Integrated electronic ignitor transformer |
|-------|--------------|------------|------------|--------------------------|--------------------------|-----|----------------|---|---|
| TGR1x | *            |            | *          | *                        |                          | *   | *              | *   | *   |
| TGR2  |              | *          | *          |                          | *                        | *   | *              | *   | *   |

## TECHNICAL DATA

|  |                                |
|--|--------------------------------|
| <b>Supply voltage:</b>                     | 220-240V @ 50-60Hz             |
|  | on request: 110-120V @ 50-60Hz |
| <b>Power consumption:</b>                  | 75 VA <sup>(1)</sup>           |
| <b>Operating temperature range:</b>        | -20°C ÷ +60°C                  |
| <b>Ambient humidity:</b>                   | 95% max at 40°C                |
| <b>Protection degree:</b>                  | IP 00                          |
| <b>Classification according to EN 230:</b> | F T C L X N                    |
| <b>Internal fuse rating:</b>               | 6,3A slow blow                 |
| <b>External fuse rating:</b>               | 4,0A fast                      |
| <b>Weight:</b>                             | 320 g                          |

<sup>(1)</sup> For device with option X the power consumption is 8 VA.

### Times:

|   |              |
|---|--------------|
| <b>Prepurge time (TV):</b>                    | 1,5 ... 40 s |
| <b>Safety time (TS):</b>                      | 5 ... 10 s   |
| <b>Dropout time on running flame failure:</b> | < 1 s        |

**Note:** The times given on the burner control label correspond to the values guaranteed. The actual values slightly differ from the values given, as prepurge time can be longer and safety time shorter than their nominal values.

### Contact rating:

|                                       |                        |
|---------------------------------------|------------------------|
| <b>Thermostat:</b>                    | 6,0 A $\cos\phi > 0,4$ |
| <b>Fan motor:</b>                     | 2,0 A $\cos\phi > 0,4$ |
| <b>EV1:</b>                           | 0,5 A $\cos\phi > 0,4$ |
| <b>EV2:</b>                           | 0,5 A $\cos\phi > 0,4$ |
| <b>Pre-heater:</b>                    | 0,5 A $\cos\phi = 1,0$ |
| <b>External ignitor transformer:</b>  | 1,0 A $\cos\phi > 1,0$ |
| <b>Lock-out alarm: <sup>(1)</sup></b> | 1,0 A $\cos\phi = 1,0$ |

<sup>(1)</sup> Only in versions without option R.

### Integrated ignitor transformer:

|   |                |
|---|----------------|
| <b>Number of poles:</b>                         | 2              |
| <b>Output peak voltage kV: <sup>(1)</sup></b>   | 2x12 kV        |
| <b>Rated output voltage:</b>                    | 2x(2.8÷3.3) kV |
| <b>Output peak current:</b>                     | 75 mA          |
| <b>Rated output current:</b>                    | 30 mA          |
| <b>Output voltage frequency: <sup>(1)</sup></b> | 8.5 kHz        |
| <b>Output voltage frequency: <sup>(2)</sup></b> | 12 kHz         |
| <b>Duty cycle:</b>                              | 33% on 3 min.  |
| <b>Recommended distance from electrode:</b>     | 3 ÷ 5 mm       |
| <b>Maximum length of the ignitor cable:</b>     | 1.5 m          |

<sup>(1)</sup> No-load output and 30 pF load.

<sup>(2)</sup> Short circuit output.

## CONTROLS FOR SPECIAL APPLICATIONS

On request it is possible to meet special requirements concerning times and operating cycles.

## CONSTRUCTION

The particular construction and the use of surface mounted components allow to have reduced overall dimensions.

The enclosure made of plastic material protects the control from possible damages resulting from crashes, incautious opening, dust and contact with the external environment.

A varistor protects the control from voltage transients on the electric network.

An inbuilt fuse protects the internal relays of the control box in case of short circuit on the outputs (valves, ignition transformer, motor and lockout signal).

KOMPACT types TGRx, with integrated electronic ignitor transformer, include an EMI suppressor filter against the electromagnetic disturbances generated from the spark.

A resistor in series to lock-out signalling output can be mounted to protect the control against reset push-button reversed connection.

## OVERALL DIMENSIONS

The following figure (Fig.1) shows the overall dimensions of the control.

**Note:** all the measures are expressed in mm.

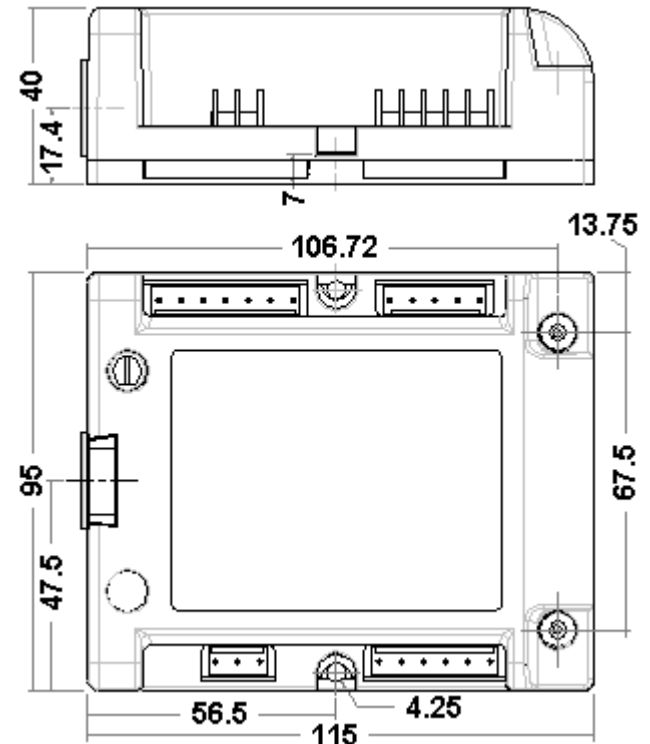

Fig. 1 – Overall dimensions

## CONNECTION

The use of non-reversible connectors with a different number of poles makes the connection easy and reliable.

For a correct operation of the ignitor transformer it is recommended to respect the distance between the electrodes and the maximum length of cables as described in the section "TECHNICAL DATA".

To reduce the radiated electromagnetic disturbances it is recommended to use a wire-wound power resistor with a value between 1kΩ and 4.7kΩ: this component will have to be inserted between each cable and its correspondent electrode.

The connectors to use for standard wiring, shown in fig. 2, can be provided as accessory.

For the electrical connection of the external components see "CONNECTION DIAGRAMS" paragraph.

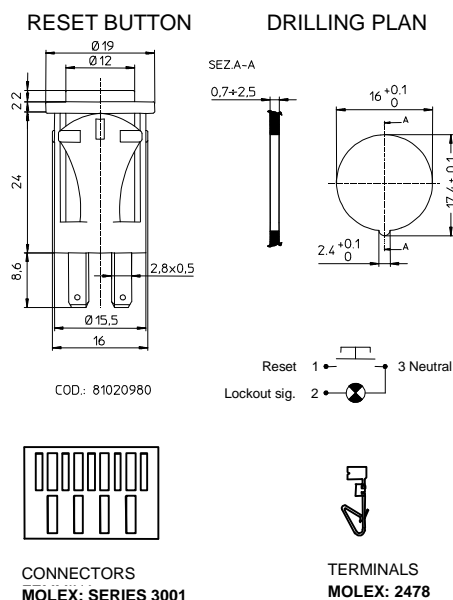

Drilling plane FC13-FC14

Drilling plane FC11

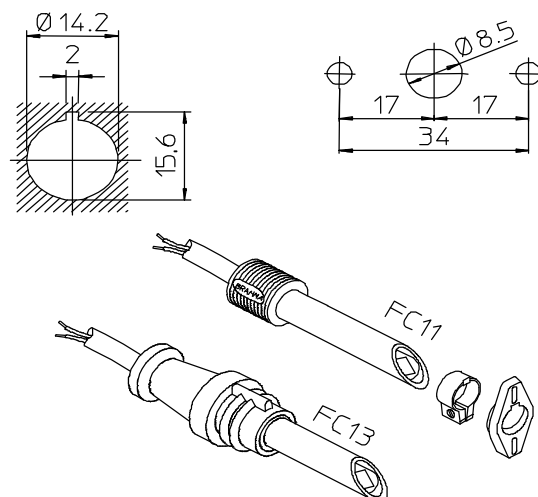

Fig. 2 – Accessories for the connection

**ACCESSORIES**

The following data are useful to choose the most suitable flame detector for the application.

|                          | Flame detectors                            |
|--------------------------|--|
| Frontal and lateral side | FC11/R 1,5..6,5 lux<br>FC11/A 1,5..3,0 lux |
| Frontal and lateral side | FC13/R 1,5..6,5 lux<br>FC13/A 1,5..3,0 lux |

The suffix indicates the colour of the photocell enclosure:

|    |      |
|----|------|
| /A | Cyan |
| /R | Red  |

To fix the flame detector type FC11 screws diameter 4mm are suggested.

For blue flame burners, FD1 and FD2 UV sensor are suitable to detect ultraviolet light (spectral field from 290 nm to 350 nm).

|              | Flame sensor |
|--------------|--------------|
| Frontal side | FD1          |
| Lateral side | FD2          |

Figure 3 shows the types and fixing systems of the FD1 and FD2 flame detectors.

To fix FD1 and FD2 flame detectors screws diameter 4 are suggested.

The following figures (Fig. 3 and Fig. 4) show the types and fixing systems of the available flame detectors.

FC14

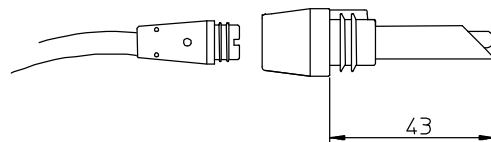

Fig. 3 – Types and fixing systems of the flame detectors

Drilling plane FD1-FD2

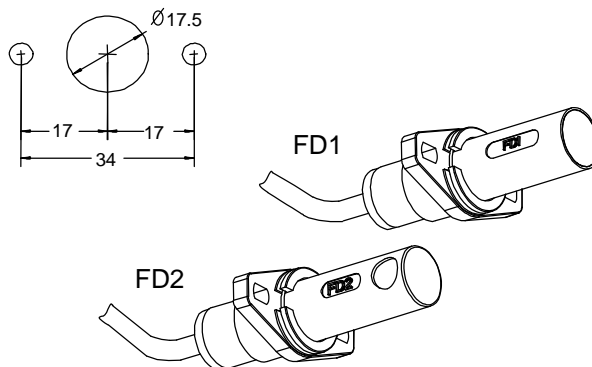

Fig. 4 – Types and fixing systems of the flame detectors FD(1-2)

**DIRECTIONS FOR USE**

- Automatic controls are safety devices and must not be opened. The manufacturer's responsibility and guarantee are invalidated if the control is incautiously opened.
- For safety reasons a regulation shutdown must occur every 24 hours (systems for non permanent operation).
- The control can be connected and disconnected only without the main power.
- The control can be mounted in any position.
- Avoid exposing the control unit to dripping water.
- Ventilation and the lowest temperature ensure the longest life of the control.
- Make sure that the type (code and times) you are using is correct before installing or replacing the control.

**ELECTRICAL INSTALLATION**

- The applicable national and European standards (e.g. EN 60335-1/EN 50165) regarding electrical safety must be respected.
- **Live** and **Neutral** should be connected correctly; a mistake could cause a dangerous situation, as the internal safety devices can be ineffective in case of insulating leakage of the connecting wires of thermostats and valves.
- Before starting the control unit check the cables carefully. Wrong connections can damage the control and compromise the safety of the application.
- The **earth** terminal of the control, the metal frame of the burner and the **earth** of the electric system must be well connected.
- Avoid putting detection cables close to power or ignition cables.
- Protect the control with a quick acting fuse suitable to the load connected and never exceeding 4A.
- The appliance in which the control is installed must provide adequate protection against the risk of electrical shock.
- The heat demand of the controller must be managed through a voltage-free contact device by employing one of the two configurations illustrated in the following connection diagrams:

**Heat Demand – connection diagrams**

*Demand managed through a voltage-free contact device by using the appropriate input of heat demand (terminals 1 and 2 of J1).*

*Demand managed through a voltage-free contact device by using the power supply line (terminals 1 and 2 of J1 are fitted with jumpers) \**

\* **Note:** employing this configuration doesn't allow to visualize the controller lock-out status in case of demand failure.

**CHECKING AT START**

Always check the control before the first start and also after any replacement or a long period of non operation of the system.

Before any ignition attempt make sure that the combustion chamber is free from oil.

Then make sure that:

- if the starting attempt occurs with the flame detector obscured the control performs a lockout after safety time;
- if start up takes place with extraneous light the control performs a lockout within 10 seconds;
- when the flame detector is obscured in running position, supply to the oil valves is interrupted within 1 second and after a recycling the control proceeds to lockout;
- the intervention of limiters or safety devices cause a safety shutdown according to the application;
- operating times and sequence are suitable to the control unit used.

**OPERATION**

At every start the control unit supplies the burner motor and the ignition transformer and proceeds to a self-checking of its own components. During the prepurge time the internal circuit makes a test of the flame signal amplifier circuit. Extraneous light or a fault in the amplifier leading to the same condition cause the lockout of the control within 10 seconds.

At the end of prepurge time the control output of the first oil valve is energized; if a flame signal is detected at the end of safety time, the control unit deenergizes the ignition transformer and goes to running position.

At the end of safety time in the controls with two flame levels the ignition transformer is deenergized and the second oil valve is supplied. If no flame signal is detected during safety time, the control goes to lockout, so the control outputs of the valve(s), the ignition transformer and the burner motor are switched off while the lockout signal is supplied.

The controls prearranged for the use of an oil pre-heater supply the pre-heater when the room thermostat and/or the boiler thermostat switch off. In this way, the starting sequence begins.

With the option "Z" the thermostat opening does not cause the burner shutdown; if the pre-heater is used with controls without option "Z", the thermostat opening causes the repetition of the starting sequence after the heating stage (RISC) of the pre-heater.

The attached operating cycles are useful to understand how each control operates.

**Abnormal operation – Extraneous light**

All control units of this series perform a lockout within 10 seconds.

**Reset of the control**

When a control has gone to lockout, a delay of 10 seconds should be considered before attempting to reset the control unit; if this time is not observed the control may not reset.

### Testing the flame signal

It is extremely important to test the flame signal level before having the burner operate.

Thanks to a voltmeter, the flame signal can be measured between terminal n° 3 and terminal n° 2 of the connector J4: with the burner in running position, the voltage between terminals must be  $\leq 0,8V$ . This value guarantees a safe operation; it corresponds to a light intensity 50% beyond the limit value (about 1,4 V). In case the tested voltage is higher, try to better orientate the photocell or to clean it (see Fig.5).

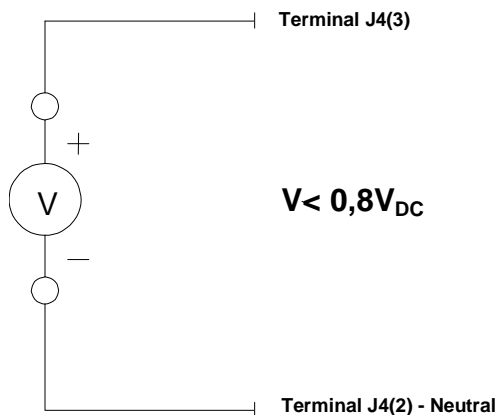

Fig. 5 – Testing the flame signal: measurements setup



### NOTES TO DISPOSE THE DEVICE

Containing electronic components, the control unit cannot be disposed as a domestic rubbish.

For a correct disposing of the device, it is necessary to consult the local references concerning the special rubbishes.

# CONTROLS DENOMINATION

| Type |     | Options |     |     |     |
|------|-----|---------|-----|-----|-----|
| TGR  | (1) | (2)     | (3) | (4) | (5) |

## Type description

- (1) Oil valves
- |   |                               |
|---|-------------------------------|
| 1 | One oil valve (single flame). |
| 2 | Two oil valve (dual flame).   |

## Options description

### (2) Operation in case of pre-heating thermostat opening

- |                  |  |
|------------------|--|
| <b>No letter</b> | <u>Standard mode</u> . The device exits from running position in case of pre-heating thermostat opening. |
| <b>Z</b>         | Normal operation in case of pre-heating thermostat opening.  |

**NOTE: the option "Z" is not available for the versions with the second gas valve (TGR2).**

### (3) Connections

- |                  |   |
|------------------|---|
| <b>No letter</b> | <u>Standard mode</u> . Connectors with fast-on terminals. |
| <b>E</b>         | Low-profile connectors.                                   |

### (4) Protection against reset push-button reversed connection

- |                  |  |
|------------------|--|
| <b>No letter</b> | <u>Standard mode</u> . Resistor in series to lock-out signal is NOT present. |
| <b>R</b>         | Internal resistor in series to lock-out signal is present.                   |

### (5) Ignitor transformer

- |                  |   |
|------------------|---|
| <b>No letter</b> | <u>Standard mode</u> . Integrated electronic ignitor transformer. |
| <b>X</b>         | Remote ignitor transformer.                                       |

# CONNECTION DIAGRAMS

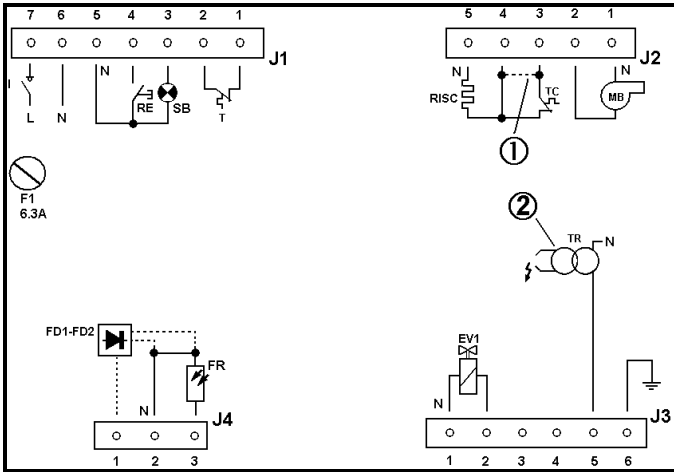

Types TGR1 - TGR1/Z

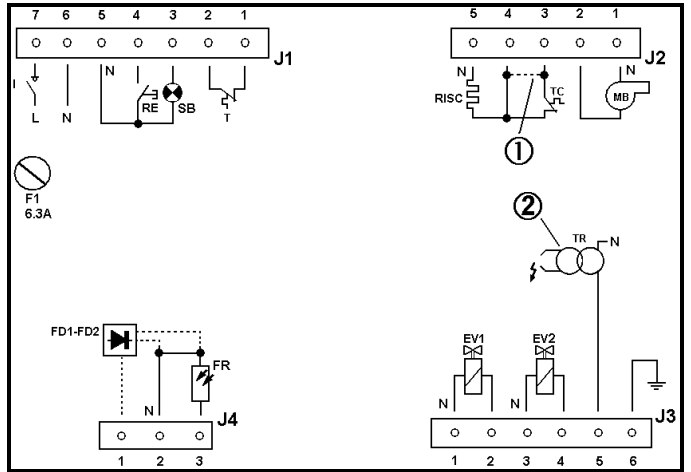

Type TGR2

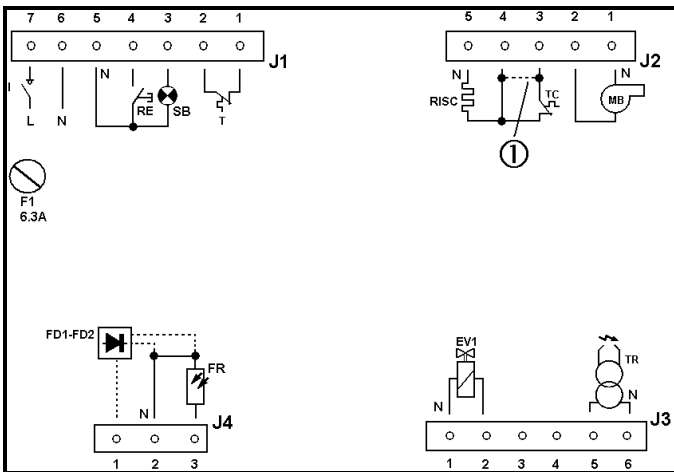

Types TGR1 - TGR1/Z (opt. X)

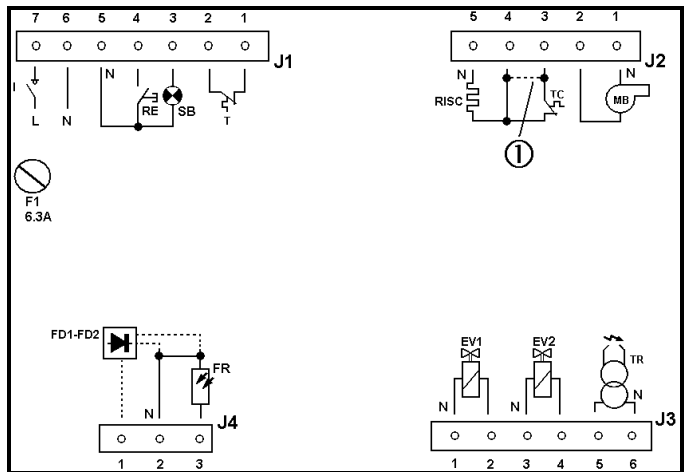

Type TGR2 (opt. X)

**NOTE:**

- (1) This connection must be inserted in case of the pre-heater switch is not mounted.
- (2) The pin no. 5 of the J3 connector can be used to energize an auxiliary external ignition transformer

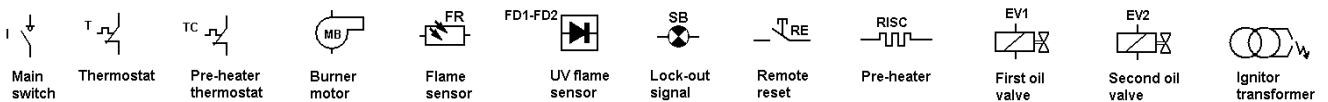

# OPERATING CYCLES

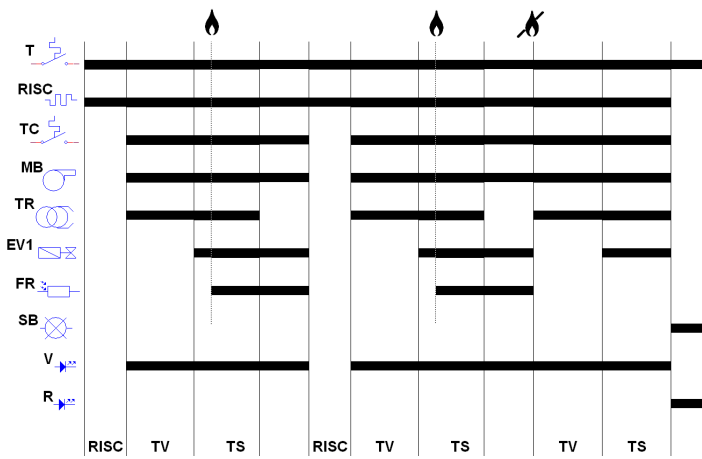

*Type TGR1*

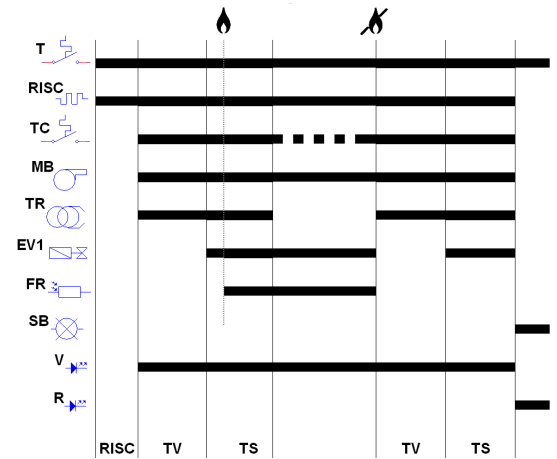

*Type TGR1/Z*

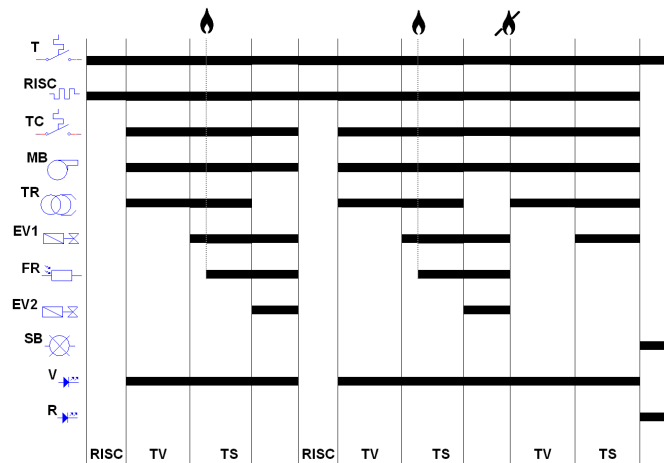

*Type TGR2*



**ATTENTION-> Company Brahma S.p.A. declines any responsibility for any damage resulting from the Customer's interfering with the device.**

**BRAHMA S.p.A.**  
 Via del Pontiere, 31/32  
 37045 Legnago (VR) - ITALY  
 Tel. +39 0442 635211 - Telefax +39 0442 25683  
<http://www.brahma.it>  
 E-mail : brahma@brahma.it

07/08/01 Subject to amendments without notice